



KENWOOD

TS-590S USB Audio Setting Manual

Kenwood Corporation
© October/15/2010

Contents

1. About the TS-590S USB Audio Function	3
2. Operation Using the USB Audio Function	4
3. Installing the ARUA-10 Software	5
3.1 System Requirements	5
3.2 Installation	5
3.3 About Virtual COM Port Driver	5
4. Settings.....	7
4.1 Transceiver Settings	7
4.1.1 Setting Up an Audio Input Route from the Rear Terminal	7
4.1.2 Audio I/O Level Settings.....	7
4.1.3 Mixed Beep Setting to External Audio Outputs.....	7
4.1.4 Data VOX Settings	8
4.1.5 Data VOX Delay Time Setting	8
4.1.6 Data VOX Gain Setting	8
4.1.7 Allocating DATA SEND Functions to PF Keys	8
4.2. Setting Transmission Methods for Audio Input to the Rear Terminal	9
4.3 ARUA-10 Settings.....	10
5. Limitations IMPORTANT !	12
5.1 USB Port Connectivity Limitations	12
6. Frequently Asked Questions	13

Disclaimer:

All efforts have been made regarding the accuracy of the contents described in this document. However, there is a possibility of misprints and of descriptions that may cause misunderstanding. Kenwood Corporation bears absolutely no responsibility for damages arising thereof.

Kenwood Corporation may revise and amend the products information described in this document without notice. Kenwood Corporation bears absolutely no responsibility for damages arising thereof.

- Windows is a registered trademark or trademark of Microsoft Corporation in the United States and other countries.
- .NET Framework is a registered trademark or trademark of Microsoft Corporation in the United States and other countries.
- Bluetooth is a registered trademark or trademark of Bluetooth SIG, Inc.
- The names of all products described hereafter are the trademarks or registered trademarks of their respective manufacturers.
- ® and ™ are omitted throughout the text.

1. About the TS-590S USB Audio Function

When the TS-590S is connected to the computer using a USB cable, the USB audio function can be used to play incoming audio over the computer speakers and transmit audio from the computer microphone.

This setup guide explains how to set up the TS-590S to use its USB audio function and how to use the ARUA-10 software to control input/output routes of the USB audio signals from a computer.

Important

- USB audio may be delayed due to unavoidable principles. Consequently, do not perform operations (such as contests or pile-ups requiring quick responses) for which delays are likely to be a problem.
- Refer to Chapter 5 "Limitations" for other limitations.
- To use the USB audio function, knowledge not only of transceivers but also of computers is required. Kenwood does not offer support for purchasing computers or for customer's computers.
- Kenwood Corporation shall bear no responsibility for related damage such as damage caused by missed communications and dialog opportunities due to incorrect customer settings, nonconformances, or misoperations as a result of using this document or the ARUA-10 software.

2. Operation Using the USB Audio Function

Operation using the USB audio function is explained using the diagram below.

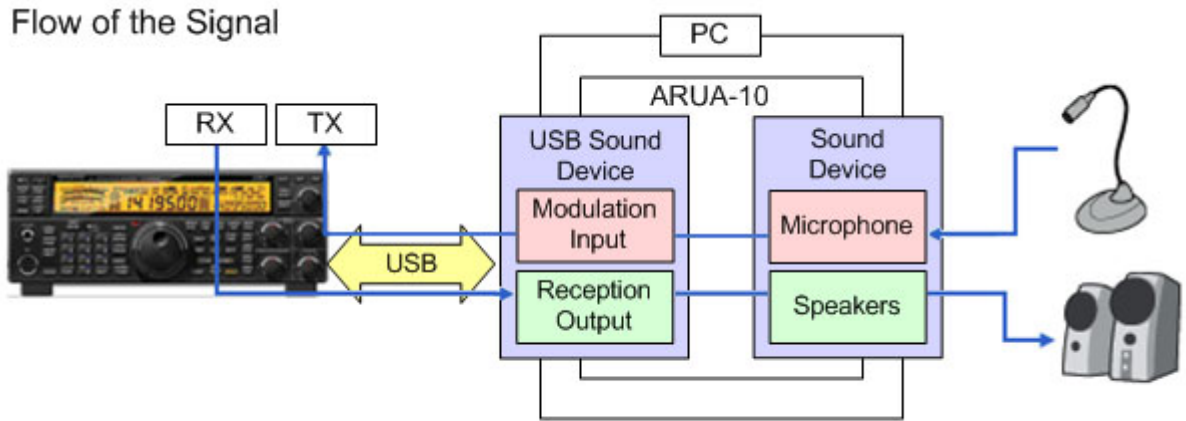

Diagram 1: Operation Using the USB Audio Function

The left side of the diagram shows the TS-590S unit while the area in the square on the right side indicates the computer. The TS-590S and the computer are connected by a USB cable. The microphone and speakers connected to the computer are shown on the far right.

Audio reception is explained first. Incoming audio from the TS-590S is sent to the computer via the USB cable and played over the speakers connected to the computer.

A signal pathway on the computer to connect the USB audio device input signals and output from the audio device connected to the speaker is necessary.

Audio transmission is explained next. Audio input from the microphone connected to the computer passes through the USB cable and is transmitted by the TS-590S unit.

A signal pathway on the computer between input signals from the audio device connected to the microphone and output from the USB audio device is necessary.

The ARUA-10 software serves as a bridge for these signal paths within the computer.

The ARUA-10 software lets you select which speaker and microphone are used for transceiver operations when there are multiple speakers and microphones connected to the computer.

3. Installing the ARUA-10 Software

3.1 System Requirements

In order to use the ARUA-10 software, your computer must meet the following requirements.

Chart 1 - Computer Requirements

Category	Specifications
CPU	CPU must exceed performance recommended for your operating system
MEMORY	System memory must exceed that recommended for your operating system
HDD	Over 100 MB free space
CD-ROM/ DVD-ROM Drive	Not required
USB Port	When using the system described above, a single USB 2.0 port
Input/Output Devices	Keyboard, mouse, microphone, speakers
Display	XGA (1024 × 768) or above
Sound	Required
OS	Windows XP (SP3 or later) Windows Vista (SP1 or later, 32-bit only) Windows 7(32-bit or 64-bit) Not compatible with other operating systems

3.2 Installation

Download and install the ARUA-10 software from the following Kenwood website:

http://www.kenwood.com/i/products/info/amateur/software_download.html

When connecting the TS-590S to a computer using a USB cable for the first time, drivers required for the USB Audio Function are automatically installed.

If you are using an ARCP-590 and Computer Control Command, you must install the “Virtual COM port driver” to connect the TS-590S with a USB cable.

Download and install the driver from the following Kenwood website:

http://www.kenwood.com/i/products/info/amateur/software_download.html

3.3 About Virtual COM Port Driver

When connecting the TS-590S to a computer with a USB cable for the first time, the “New Hardware Detected Wizard” message appears. This is the install prompt for the Virtual COM Port.

If you are not using an ARCP-590 or Computer Control Command, there is no need to install the Virtual COM Port. However, if it is not installed, the Wizard message appears every time the USB cable is connected, so we recommend installation.

When the “New Hardware Detected Wizard” message appears and you have not yet installed the Virtual COM Port, click “Cancel” and install the Virtual COM Port before continuing.

For details on how to install the Virtual COM Port please visit the download page noted above.

4. Settings

4.1 Transceiver Settings

Complete the necessary transceiver (TS-590S) settings before using the USB audio function. (Refer to the user manual for how to use the TS-590S.)

4.1.1 Setting Up an Audio Input Route from the Rear Terminal

On the rear terminal there are two types of audio input routes - the ACC2 connector route and the USB connector route for using the USB audio function. Make the following menu settings to transmit audio input from the USB connector.

Menu No.	Function	Set value
63	Audio input line selection for data communications	USB

The default setting is ACC2.

4.1.2 Audio I/O Level Settings

Use the following menu to adjust audio transmission input levels from the PC, and receive audio output levels to the PC.

Menu No.	Function	Setting range
64	Audio level of USB input for data communications	0 to 9
65	Audio level of USB output for data communications	0 to 9

The default value for all settings is 4.

4.1.3 Mixed Beep Setting to External Audio Outputs

With the TS-590S default mode, only received audio signals that do not include beeps or side tones are output as audio signals from the ACC2 connector and the USB connector as USB audio signals.

Make the following menu settings to output the same audio as the audio output from the wireless speaker, including beeps and side tones, externally.

Menu No.	Function	Set value
68	Mixing beep tones for ACC2/USB audio outputs	ON

The default setting is OFF.

Reference:

To implement data communications, turn this function OFF.

4.1.4 Data VOX Settings

Set whether or not to use the VOX function for the audio output from the rear terminal.

Menu No.	Function	Set value
69	Data VOX	ON or OFF

The default setting is OFF.

Caution:

- When this function is ON, all sounds created by the computer other than the intended audio transmissions are also transmitted, so be careful.
- When using this function for the first time, we recommend connecting a dummy load to the TS-590S to perform checks and adjustments.

4.1.5 Data VOX Delay Time Setting

Set the VOX Delay Time Setting when using the Data VOX function.

Menu No.	Function	Setting range
70	Data VOX delay time	0 to 100

The default setting is 50.

4.1.6 Data VOX Gain Setting

Set the VOX Gain Setting when using the Data VOX function.

Menu No.	Function	Setting range
71	Data VOX gain for the USB audio input	0 to 9

The default setting is 50.

4.1.7 Allocating DATA SEND Functions to PF Keys

Set the DATA SEND functions to the PF keys to test the transmission of audio input from the rear terminal. In this example, the [PF A] key has been set.

Menu No.	Function	Set value
79	Front panel PF A key assignment	205

The default setting is 200 (VOICE1).

Using the [PF] keys, which set the DATA SEND functions, enables switching between transmit and receive modes for audio input from the rear terminal.

4.2. Setting Transmission Methods for Audio Input to the Rear Terminal

The [SEND] keys on the PTT of the microphone connected to the TS-590S, and on the TS-590S control panel, are the method for transmitting audio input to the microphone connected to the TS-590S, so even if these operations are implemented, audio entered as audio signals from USB cannot be transmitted.

To transmit audio input as audio signals from the USB, select one of the following methods.

- Transmitting using the ARCP-590

With the ARCP-590, settings must be done to transmit audio input through the rear terminal to use the on-screen [SEND] key.

Select "Setup TX control" from the ARCP-590 "Tool" menu. The "Setup TX control" window is displayed.

In the window above, select "ACC2/USB" in the "Modulation line" setting, and then select "USB".

For further details refer to the ARCP-590 help. (ARCP-590 details are downloadable from the Kenwood website.)

- Use the ACC2 Connector's PKS port to transmit.

This setting allows you to transmit audio received by the rear terminal by setting the PKS port in the ACC2 Connector on the back of the TS-590S to "Low."

For details of the connector and terminal specifications, refer to the TS-590S instruction manual.

- Use the PF key assigned to the DATA SEND function to transmit.

By assigning the PF key to the DATA SEND function, the PF key can be used to transmit audio received by the rear terminal

For details, refer to "4.1.7 Allocating DATA SEND Functions to PF Keys".

4.3 ARUA-10 Settings

Follow the steps below to set up the ARUA-10

- ① Connect the TS-590S and computer using a USB cable.
- ② To launch the software, select Start Button > Programs > Kenwood > ARUA-10.
- ③ After launching the ARUA-10, a “Task Tray” icon  appears. Right click this icon and select “Device Settings” from the menu. The window shown below appears.

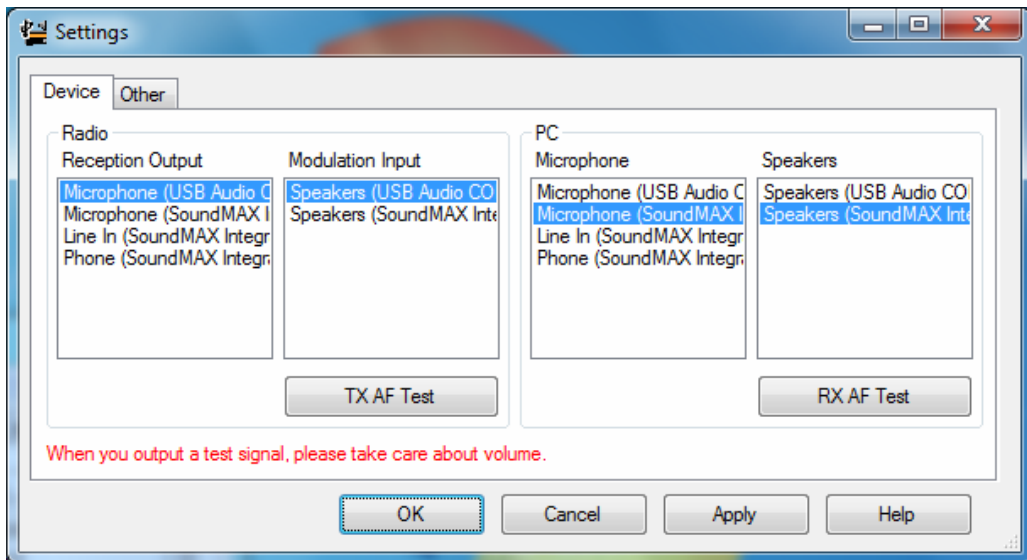

In this window you can specify sound devices for the transceiver’s audio reception output and modulated audio input. You can also specify which microphones and speakers connected to the computer to use.

In the above example, the computer has recognized four types of input sound devices.

- Microphone (USB Audio Codec)
- Microphone (SoundMAX Integrated Digital Audio)
- Line In (SoundMAX Integrated Digital Audio)
- Phone (SoundMAX Integrated Digital Audio)

There are two types of output sound devices.

- Speakers (USB Audio Codec)
- Speakers (SoundMAX Integrated Digital Audio)

* The items listed depend on the operating system and sound devices used.



- ④ On the far left of the window, from the “Radio” section set the “Reception Output”. This is where the input is set for audio received from the transceiver. As audio reception comes into the computer as USB audio, select “Microphone (USB Audio Codec).”
- ⑤ In the second section on the left side of the window, set the “Modulated Input” in the “Radio” section. This is where the output is set for sending audio transmissions to the transceiver. As transmissions are sent to the transceiver as USB audio, select “Speakers (USB Audio Codec).”
- ⑥ In the third section from the left side of the window, set the “Microphone” in the “PC” section. This is where the computer microphone used for audio input to be transmitted is set. In the above example, “Microphone (SoundMAX Integrated Digital Audio)” is selected.
- ⑦ On the far right of the window in the “PC” section, set the “Speakers” device. This is where the computer speakers used for playing incoming audio are specified.

Clicking the “RX AF Test” button plays a test signal from the selected speaker.

Next, follow the steps below, to confirm that the intended audio transmission route is configured.

- ⑧ Connect the dummy load to the TS-590S.
- ⑨ If the TS-590S is in Split mode, switch to Simplex mode, with the mode set to SSB (USB or LSB).
- ⑩ Enable the transmission monitor function.
- ⑪ Press the PF key set to the DATA SEND function to transmit.
- ⑫ From the ARUA-10 window shown above, click the “TX AF Test” button. If test signals are played from the internal TS-590S speakers, the system is set up correctly. Push the PF key set to the DATA SEND function to return to audio reception mode.

If the test signal does not play, check the settings and try the test again.

- ⑬ From the ARUA-10 window, click the “OK” button to complete the setup.
- ⑭ Right-click on the  icon in the task tray to display the menu. From the menu, select “Start”. The icon in the task tray changes to  and ARUA-10 starts.

5. Limitations **IMPORTANT !**

5.1 USB Port Connectivity Limitations

If the PC and TS-590S are connected via a USB cable, audio transmissions can be transmitted using the USB audio function. In principle, however, there is a delay with USB audio signals, plus sound may be delayed or lost depending on the PC performance and load status. Therefore, do not perform operations for which delays are likely to be a problem (such as contests or communications requiring quick responses).

Also, when connected with the USB cable, alert sounds from other software or audio from music or videos may not play over the computer speakers.

Furthermore, **when the DATA VOX function of the transceiver is “ON” and the computer and transceiver are connected with the USB cable, the transceiver may send sounds emitted by the computer. To avoid unintended transmissions when the computer and transceiver are left connected via USB, set the DATA VOX function to “OFF.”**

Depending on the combination of PC and sound functions, the USB audio function may not operate correctly. Kenwood does not offer support for customer computers.

6. Frequently Asked Questions

This section introduces questions that have been asked to date, and subjects verified by Kenwood Corporation.

	Question	Answer
Installation	Where can I get the USB audio drivers?	You do not need to download the drivers. When the computer and TS-590S are connected via USB for the first time, the standard driver for your operating system is automatically installed.
	There appear to be many limitations. Is it actually possible to operate using the USB Audio Function?	Although it may not run exactly the same, if you get used to it, general communication on a practical level is possible. The point is to become accustomed to the delays particular to USB audio. You may have some initial confusion with issues like the standby timing.
	Can I use a USB or Bluetooth headset?	You can use a USB or Bluetooth headset. However, due to unavoidable delays using these devices it takes time for spoken audio to be transmitted. Also, time is required for received audio to reach the headphones. We do not recommend use of these devices when such delays can cause problems.
Operation	There is static in the audio transmissions. Audio transmission and reception levels are low.	The USB audio input/output levels are not appropriately set. Please adjust the settings via Menu Nos. 64 and 65 on the TS-590S.
		This may also depend on the specifications of the sound device used in your computer. Try using another sound card or USB sound device.
		The sound device driver may need to be upgraded. Try checking for new versions and upgrade the driver.

	<p>I cannot hear audio from the transceiver over the computer speakers.</p>	<p>It is possible that the USB audio output level from the TS-590S is too low. Try adjusting Menu No. 65.</p> <p>If there is a mistake in the ARUA-10 settings, audio reception sent by USB audio to the computer is not played from the computer speakers. Refer to “4.3 ARUA-10 Settings” and check the settings.</p> <p>The volume setting of the computer speakers or headset may be too low. Try adjusting the volume settings.</p>
<p>Operation</p>	<p>Even though the transceiver is in transmission mode, I cannot transmit voice input from the computer microphone.</p>	<p>If the audio input route from the rear terminal of the TS-590S is set to ACC2, USB audio input received by the TS-590S is not transmitted. Refer to “4.1.1 Setting Up an Audio Input Route from the Rear Terminal” and check the settings.</p> <p>When transmitting using the TS-590S microphone PTT or “SEND” key, USB audio received by the TS-590S is not transmitted. When using the ARCP-590, the “Transmission Controls Settings” are required. Refer to “4.2 Setting Transmission Methods for Audio Input to the Rear Terminal” and check the settings.</p> <p>If there is a mistake in the ARUA-10 settings, USB audio input to the TS-590S is not transmitted. Refer to “4.3 ARUA-10 Settings” and check the settings.</p> <p>If the computer microphone or headset is muted, audio is not sent from the computer. Please check your computer’s sound function settings.</p>

	The transceiver does not transmit VOX when audio input is from the computer microphone.	In order to transmit VOX when voice data input is received through the rear terminal, specific menu settings are required. Refer to “4.1.4 Data VOX Settings” and “4.1.6 Data VOX Gain Setting” and check the settings.
Operation	The end of audio transmissions are cut off. The system switches back to audio reception before sending all of an audio transmission.	When using the ARCP-590, if you quickly switch to receive mode after using the computer’s microphone to transmit, you may have switched before the audio is transmitted because of the delay in transmitting an audio signal via USB. If this happens, it may be possible to avoid such delays by slightly changing the method of operation, as described below. <ul style="list-style-type: none"> ▪ After transmission, watch the power and ALC meters and wait until the audio input to the transceiver finishes before switching back to reception mode. ▪ Use the DATA VOX function. Use a regular stereo jack instead of a USB or Bluetooth headset.

	Question	Answer
Operation	<p>The transceiver transmits, even with no voice input from the microphone, when the DATA VOX function is set to ON.</p> <p>Turning the DATA VOX to ON causes the transceiver to transmit, even when the microphone is not connected.</p> <p>The transceiver transmits without my knowledge.</p>	<p>When the DATA VOX function is ON, for laptop computers with internal microphones, sounds near the computer that are loud enough to trigger the VOX are sent to the transceiver and transmitted by VOX. Or sounds from other software may be sent to the transceiver and transmitted by VOX.</p> <p>Please try the following.</p> <ul style="list-style-type: none"> ▪ Refer to “4.1.6 Data VOX Gain Setting” and adjust the VOX Gain. ▪ Use a headset. ▪ While operating the transceiver, do not use other software. <p>If the above methods do not work, turn OFF the DATA VOX function.</p> <p>Also, when the computer is left connected to the transceiver using the USB cable, sounds from other software, such as alerts, music and video are transmitted to the transceiver and sent by VOX unintentionally.</p> <p>If you leave the computer and transceiver connected using a USB cable please turn OFF the DATA VOX before using your computer.</p>
	<p>Reception quality depends on the device.</p>	<p>Voice audio is affected by voice encoding and the quality may differ from the original voice reception quality. This is part of the USB sound function specifications and is unavoidable.</p>
	<p>I can hear the beeping and voice guidance audio from the transceiver on the computer. Alternatively, I want to be able to hear them, but can't.</p>	<p>This can be configured in the transceiver menu.</p> <p>Please refer to “4.1.3 Mixed Beep Settings to External Audio Outputs”.</p>

	Question	Answer
Other FAQs	Is ARUA-10 required when using KNS (remote operation over a network)?	ARUA-10 cannot be used with KNS (remote operation over a network).
	Using the USB Audio Function while operating the TS-590S, the computer's standard audio can no longer be heard.	<p>When operating ARUA-10, audio reception from the transceiver is played over the computer speakers. If you want to stop audio reception, stop the ARUA-10 operation.</p> <p>Also, when not using the TS-590S, we recommend you disconnect the USB cable from the computer.</p>